

# CBCS SCHEME

USN

--	--	--	--	--	--	--	--	--	--

15ME64

Sixth Semester B.E. Degree Examination, June/July 2018

## Design of Machine Elements – II

Time: 3 hrs.

Max. Marks: 80

- Note: 1. Answer FIVE full questions, choosing one full question from each module.  
2. Use of design data hand book is permitted.

### Module-1

- 1 a. Explain the compounding in cylinders. (04 Marks)  
b. The C-frame of a 100 kN capacity press is shown in Fig. Q1 (b). The material of the frame is grey cast iron FG200 and the factor of safety is 3. Determine the dimensions of the frame. (12 Marks)

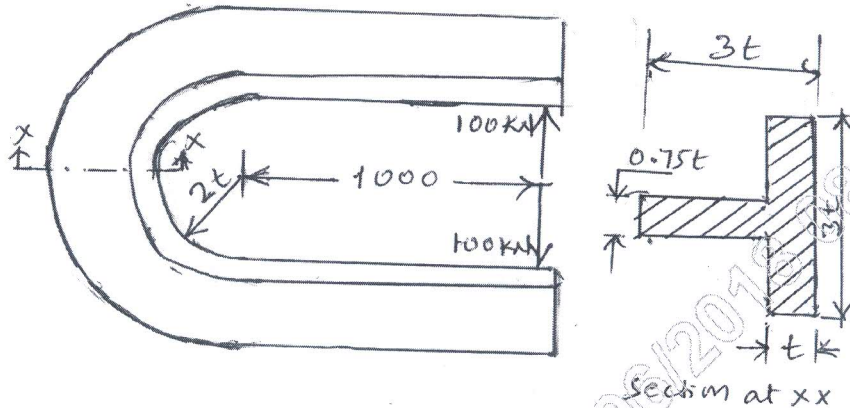

Fig. Q1 (b)

OR

- 2 a. Differentiate between a straight beam and a curved beam. (04 Marks)  
b. The inner diameter of a cylinder is 250 mm. The pressure is limited to 15 MPa. The cylinder is made of plain Carbon steel with  $\sigma_{ut} = 340 \text{ N/mm}^2$  and  $\mu = 0.27$ . Taking the factor of safety as 5, calculate the cylinder wall thickness if,  
(i) The ends are closed.  
(ii) The ends are open. (12 Marks)

### Module-2

- 3 a. Enumerate the objectives of chain lubrication. (04 Marks)  
b. A leather belt drive transmitting 15 kW power with the help of a flat belt made of leather of mass density 0.95 g/cc. The centre distance between the pulleys is twice the diameter of the bigger pulley. The smaller pulley rotates at 1440 rpm and the speed of bigger pulley is 480 rpm. The belt should operate at a velocity of 20 m/s approximately and the stresses in the belt should not exceed  $2.25 \text{ N/mm}^2$ . The coefficient of friction is 0.35. The thickness of the belt is 5 mm. Calculate  
(i) The diameter of the pulleys.  
(ii) The length and width of the belt.  
(iii) The belt tensions. (12 Marks)

Important Note : 1. On completing your answers, compulsorily draw diagonal cross lines on the remaining blank pages.  
2. Any revealing of identification, appeal to evaluator and/or equations written eg. 42+8 = 50, will be treated as malpractice.

OR

- 4 a. Explain the advantages of regular-lay ropes. (04 Marks)
- b. Determine the percentage increases in power capacity made possible in changing over from a flat belt to a V-belt drive. The diameter of the flat pulley is the same as the pitch diameter of the grooved pulley. The pulley rotates at the same speed as the grooved pulley. The coefficient of friction for the flat belt and the V-belt is the same, 0.3. The V-belt pulley groove angle is  $60^\circ$ . The belts are of the same material and have the same cross section area. In each case the angle of wrap is  $150^\circ$ . (04 Marks)
- c. A helical compression spring made of circular wire, is subjected to an axial force, which varies from 2.5 kN to 3.5 kN. Over this range of force, the deflection of the spring should be approximately 5 mm. The spring index can be taken as 5. The spring has square and ground ends. The spring is made of patented and cold-drawn steel wire with ultimate tensile strength of  $1050 \text{ N/mm}^2$  and modulus of rigidity of  $81370 \text{ N/mm}^2$ . The permissible shear stress for the spring wire should be taken as 50% of the ultimate tensile strength. Calculate  
 (i) Wire diameter (ii) Mean coil diameter (iii) Number of active coils (iv) Total number of coils (v) Solid length of the spring (vi) free length of the spring (vii) required spring rate; and (viii) actual spring rate. (08 Marks)

Module-3

- 5 It is required to design a pair of spur gears with  $20^\circ$  full-depth involute teeth based on the Lewis equation. The velocity factor is to be used to account for dynamic load. The pinion shaft is connected to a 10 kW, 1440 rpm motor. The starting torque of the motor is 150% of the rated torque. The speed reduction is 4 : 1. The pinion as well as the gear is made of plain carbon steel with  $\sigma_d$  (or  $\sigma_0$ ) =  $200 \text{ N/mm}^2$ . Take number of teeth on pinion = 18. Design the gears specify their dimensions and suggest suitable hardness. Assume carefully cut gears (Class II). (16 Marks)

OR

- 6 A pair of bevel gears with  $20^\circ$  pressure angle, consists of a 20 teeth pinion meshing with a 30 teeth gear. The module is 4 mm, while the face width is 20 mm. The material for the pinion and gear is steel ( $\sigma_0 = 250 \text{ N/mm}^2$ ). The gear teeth are lapped and ground (Class 3) and the surface hardness is 400 BHN. The pinion rotates at 500 rpm and receives 2.5 kW power from the electric motor. The starting torque of the motor is 150% of the rated torque. Determine the factor of safety against bending failure and against pitting failure. (16 Marks)

Module-4

- 7 Complete the design and determine the input power capacity of a worm gear speed reduces unit composed of a hardened steel worm and a phosphor bronze gear having  $20^\circ$  stub involute teeth. The center distance  $C$  is to be 200 mm, the transmission ratio is to be 10, and the worm speed is to be 1750 rev/min. (16 Marks)

OR

- 8 a. An automotive plate clutch consists of two pairs of contacting surfaces with asbestos friction lining. The maximum engine torque is 250 Nm. The coefficient of friction is 0.35. The inner and outer diameters of friction lining are 175 mm and 250 mm respectively. The clamping force is provided by nine springs, each compressed by 5 mm to give a force of 800 N, when the clutch is new:  
 (i) What is the factor of safety with respect to slippage when the clutch is brand new?  
 (ii) What is the factor of safety with respect to slippage after initial wear has occurred?  
 (iii) How much wear of friction lining can take place before the clutch will slip? (08 Marks)

- b. A differential band brake is shown in Fig. Q8 (b). The width and thickness of the steel band are 100 mm and 3 mm respectively and the maximum tensile stress in the band is  $50 \text{ N/mm}^2$ . The co-efficient of friction between the friction lining and the brake drum is 0.25. Calculate (i) The tensions in the band (ii) The actuating force and (iii) The torque capacity of the brake. Find out whether the brake is self locking. (08 Marks)

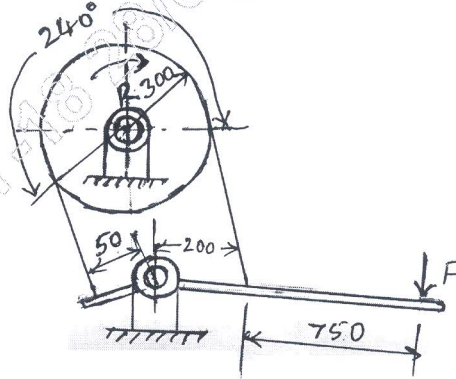

All dimensions are in mm

Fig. Q8 (b)

#### Module-5

- 9 a. List the applications of anti-friction bearings. (04 Marks)
- b. A 75 mm long full journal bearing of diameter 75 mm supports a load of 12 kN on a journal turning at 1800 rpm. Assuming a  $\frac{\gamma}{C}$  ratio of 1000, and an oil having viscosity of 0.01 kg/mS at the operating temperature, determine the coefficient of friction by using (i) the McKee equation, (ii) the Raimondi and Boyd curve (iii) also determine the amount of heat generated using the co-efficient of friction as calculated by the McKee equation. (12 Marks)

OR

- 10 a. Define hydrodynamic lubrication. Explain the principle of hydrodynamic lubrication. (06 Marks)
- b. A single row deep groove ball bearing is subjected to a radial force of 7 kN and thrust force of 2.2 kN. The shaft rotates at 1200 rpm. The expected life  $L_{10h}$  of the bearing is 20000h. The minimum acceptable diameter of the shaft is 75 mm. Select a suitable ball bearing for this application. Take  $X = 0.56$  and  $Y = 1.8$ . (10 Marks)

\* \* \* \* \*