

CBCS SCHEME

USN

--	--	--	--	--	--	--	--	--	--

17ME54

Fifth Semester B.E. Degree Examination, Aug./Sept.2020

Design of Machine Elements – I

Time: 3 hrs.

Max. Marks: 100

- Note: 1. Answer any FIVE full questions, choosing ONE full question from each module.
2. Any missing data may be suitably assumed.
3. Use of design data hand book is permitted.*

Module-1

- 1 a. Explain the phases of design process. (06 Marks)
b. What is stress concentration? Mention the reasons for stress concentration. (04 Marks)
c. A C-clamp shown in Fig.Q1(c) carries a load of 25 kN. The cross-section of the clamp is rectangular and the ratio of depth to width (d/b) is 2:1. The clamp is made of cast steel of grade 20-40 ($\sigma_y = 400 \text{ N/mm}^2$) and the factor of safety is 4. Determine the dimension of the cross section of the clamp.

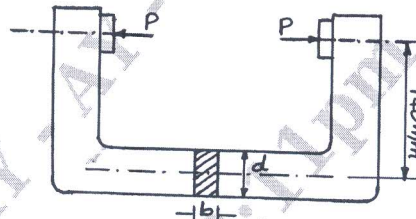

Fig.Q1(c)

(10 Marks)

OR

- 2 a. Define factor of safety. (02 Marks)
b. Mention the principal theories of elastic failures and explain any two. (08 Marks)
c. A flat plate as shown in Fig.Q2(c) is subjected to a tensile force of 10 kN. The plate material is grey cast iron FG200 ($\sigma_u = 200 \text{ N/mm}^2$) and factor of safety is 2.5. Determine the thickness of the plate.

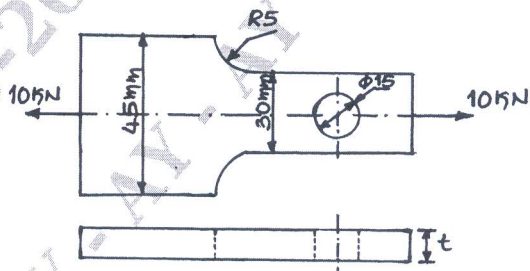

Fig.Q2(c)

(10 Marks)

Module-2

- 3 a. Derive an expression for impact stress induced in a member subjected to bending. (06 Marks)
b. Define the following :
(i) Fatigue load (ii) Range of stress
(iii) Amplitude ratio (iv) Endurance Limit (04 Marks)

- c. A weight of 1 kN is dropped from a height of 50 mm at the free end of a cantilever beam of effective length of 800 mm, selecting C40 steel ($\sigma_y = 324 \text{ N/mm}^2$) and factor of safety 3. Determine (i) Cross-section of the cantilever beam of square cross-section (ii) Impact factor. Assume modulus of elasticity as 200 GPa. (10 Marks)

OR

- 4 a. Explain the factors affecting endurance limit. (08 Marks)
 b. A steel shaft is subjected to a bending moment varies from 100 N-m to 200 N-m and transmit 10 kW at 150 rpm. The torque varies over a range of $\pm 40\%$. The shaft is made of steel whose yield stress is 400 N/mm^2 and endurance stress 300 N/mm^2 . Surface coefficient factor 0.9, size factor 1.2, factor of safety 5, stress concentration factor 1.94. Determine the diameter of shaft for infinite life. (12 Marks)

Module-3

- 5 A horizontal commercial shaft is supported by two bearings 1.5m apart. A keyed gear 20° involute and 175mm diameter is located 400mm to the left of the right bearing and is driven by a gear directly behind it. A 600mm diameter pulley is keyed to the shaft 600mm to the right of the left bearing and drives a pulley with a horizontal belt drive directly behind it. The ratio of tension of the belt is 3:1, with the slack side on top. The drive transmit 45 kW at 330 rpm. Take $C_m(k_b) = C_t(k_t) = 1.5$. Calculate the necessary diameter of the shaft. Use allowable shear stress of 40 MPa (20 Marks)

OR

- 6 a. What is Cotter? Mention the different types of Cotter Joint. (04 Marks)
 b. Design a square key for fixing a gear on a shaft of 25mm diameter. The shaft is transmitting 15 kW power at 720 rpm to the gear. The key is made of steel 50C4 ($\sigma_y = 460 \text{ N/mm}^2$) and the factor of safety is 3. For key material, the yield strength in compression can be assumed to be equal to the yield strength in tension. Determine the dimension of the key. (06 Marks)
 c. Design a rigid type of flange coupling to connect two shafts. The input shaft transmit 37.5 kW power at 180 rpm to the output shaft through the coupling. The design torque is 1.5 times rated torque. The shaft and keys are made of steel with yield strength of 380 N/mm^2 with factor of safety 2.5. flanges are made of grey cast iron FG200 with factor of safety 6. Assume ultimate shear strength is one half of the ultimate tensile strength. (10 Marks)

Module-4

- 7 a. Design a triple riveted lap joint zig-zag type, for a pressure vessel of 1.5m diameter. The maximum pressure inside the vessel is 1.5 MPa. The allowable stresses in tension, crushing and shear are 100 MPa, 125 MPa and 75 MPa respectively. (10 Marks)
 b. Determine the size of the weld required for an eccentrically loaded weld as shown in Fig.Q7(b). The allowable stress in the weld is 75 N/mm^2 .

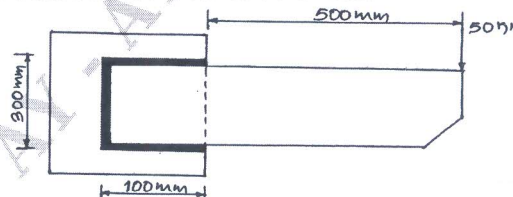

Fig.Q7(b)

(10 Marks)

OR

- 8 a. A tie bar bridge consists of a flat 350 mm wide and 20 mm thick. Design an economical double cover butt joint if the permissible stresses are $\sigma_t = 90 \text{ N/mm}^2$, $\sigma_c = 150 \text{ N/mm}^2$ and $\tau = 60 \text{ N/mm}^2$. (16 Marks)

- b. Two plates are joined by means of fillet weld as shown in Fig.Q8(b). The leg dimension of the weld is 10mm and the permissible shear at the throat cross-section is 75 N/mm^2 . Determine the length of each weld. (04 Marks)

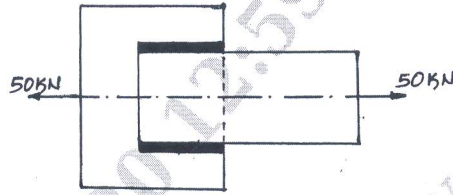

Fig.Q8(b)

Module-5

- 9 a. The base of a Pillar crane is fastened to the foundation by 8 bolts spaced equally on bolt circle diameter 1.6m. The diameter of the pillar base is 2m. Determine the size of bolt when crane carries a load of 100 kN at a distance of 5m from the centre of the base as shown in Fig.Q9(a). The allowable stress for the bolt material is 100 MPa.

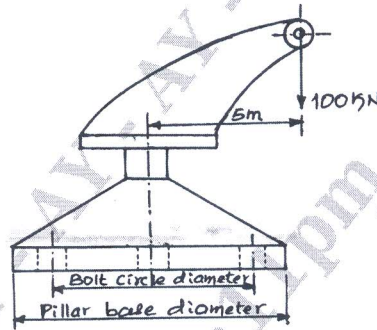

Fig.Q9(a)

(05 Marks)

- b. The square thread of a screw jack with a specification of 80×16 , with a double start is to raise a load of 100 kN. The mean collar diameter is 130mm. The coefficient of friction for the threads and the collar are 0.1 and 0.12 respectively. Determine
- Torque required to raise the load.
 - Torque required to lower the load
 - Efficiency of the screw.
 - Check for overhaul.
- (15 Marks)

OR

- 10 a. Explain self locking and overhauling in power screw. (04 Marks)
- b. Obtain the expression the torque required to lift the load in a square threaded screw. (06 Marks)
- c. The joint shown in Fig.Q10(c) is subjected to an eccentric load of 40 kN. The bolts are made of plain carbon steel having yield strength in tension of 400 MPa and the factor of safety is 2.5. Determine size of bolts.

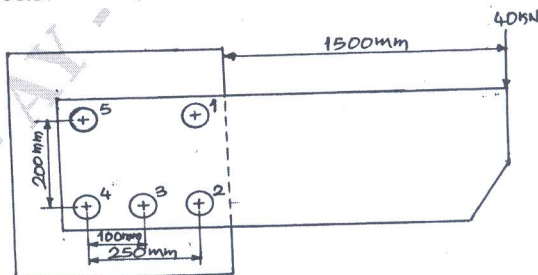

Fig.Q10(c)

(10 Marks)
