

CBCS SCHEME

USN

--	--	--	--	--	--	--	--	--	--

17CV33

Third Semester B.E. Degree Examination, Feb./Mar. 2022

Fluid Mechanics

Time: 3 hrs.

Max. Marks: 100

- Note: 1. Answer any FIVE full questions, choosing ONE full question from each module.
2. Assume missing data suitably.

Module-1

- 1 a. Differentiate between:
(i) Liquids and gasses
(ii) Real fluids and ideal fluids
(iii) Specific weight and specific gravity (06 Marks)
b. Derive an equation for the capillary rise/fall. (06 Marks)
c. In the system shown in Fig.Q1(c), if the pressure head in the pipe A is 2m of water. Find the pressure head and intensity in pipe B.

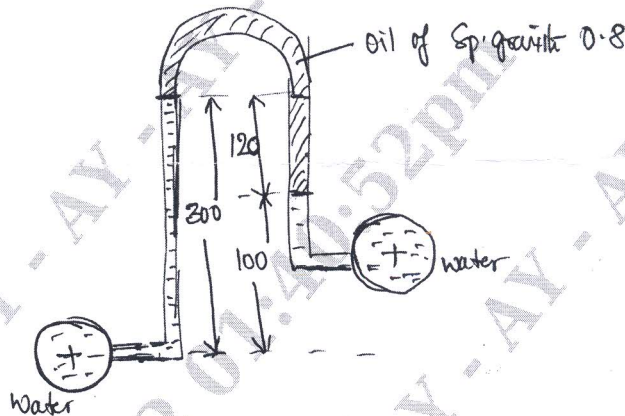

Fig.Q1(c)

(08 Marks)

OR

- 2 a. State and prove Pascal's law. (06 Marks)
b. Differentiate between:
(i) Absolute and gauge pressure
(ii) Simple and differential manometer
(iii) Piezometer and pressure gauges (06 Marks)
c. A 150 mm diameter vertical cylinder rotates concentrically inside another cylinder of diameter 151 mm. Both cylinders are 250 mm high. The space between the cylinders is filled with a liquid whose viscosity is unknown. If a torque of 12.0 Nm is required to rotate the inner cylinder at 100 rpm, determine the viscosity of the fluid. (08 Marks)

Module-2

- 3 a. Show that the centre of pressure always lies below centre of gravity for immersed surfaces in a fluid. (08 Marks)
b. Distinguish between centre of gravity and centre of pressure. (02 Marks)
c. In a two dimensional flow, the fluid velocity components are given by $u = x - 4y$ and $v = -y - 4x$. Find the velocity potential and stream function. (10 Marks)

Important Note : 1. On completing your answers, compulsorily draw diagonal cross lines on the remaining blank pages.
2. Any revealing of identification, appeal to evaluator and /or equations written eg, 42+8 = 50, will be treated as malpractice.

OR

- 4 a. State and prove continuity equation in 3 dimensional form in an incompressible fluid flow. (08 Marks)
- b. Show that streamlines and equipotential lines are orthogonal. (04 Marks)
- c. Find the horizontal and vertical component of water pressure acting on the face of a tainter gate of 90° sector of radius 4m as shown in Fig.Q4(c).

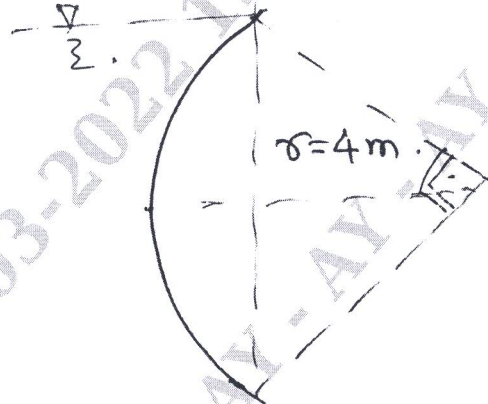

Fig.Q4(c)

(08 Marks)

Module-3

- 5 a. Derive Bernoulli's theorem from first principles. State the assumptions and the principle. (10 Marks)
- b. Find the discharge for an orifice meter with orifice diameter 100 mm inserted in a pipe of 200 mm diameter. The pressure gauges fitted to upstream and downstream of the orifice meter given the readings of 1962 N/mm^2 and 9810 N/mm^2 respectively. Coefficient of discharge is 0.6. (10 Marks)

OR

- 6 a. With a neat sketch, explain the principles of pitot tube and derive an equation to get the velocity of flow in a pipe. (06 Marks)
- b. Derive equations to obtain force exerted by flowing fluid on a pipe bend using momentum equation. (08 Marks)
- c. The water is flowing through a taper pipe of length 100 m with diameter at upper and lower ends as 600 mm and 300 mm respectively at the rate of 5 lps. The pipe has a slope of 1:30. Find the pressure at lower end if the pressure at higher level is 19.62 N/mm^2 . (06 Marks)

Module-4

- 7 a. Explain different classifications of orifice. (08 Marks)
- b. With a neat sketch, explain Borda's mouth piece. (04 Marks)
- c. A Cippoletti weir of crest length 600 mm discharges water. The head of water over weir is 360 mm, Find the discharge over the weir if the channel is 800 mm and 500 mm deep with $C_d = 0.6$. Consider velocity of approach. (08 Marks)

OR

- 8 a. Derive the equation for flow through triangular sharp crested weir with usual notations. (08 Marks)
- b. Write a note on ventilation of weirs. (04 Marks)
- c. The head of water over an orifice of diameter 40 mm is 10 m. Find the actual discharge and actual velocity at vena-contracta. Take $C_d = 0.6$ and $C_v = 0.98$. (08 Marks)

Module-5

- 9 a. Distinguish between major and minor losses. (04 Marks)
b. Derive an expression for fluid flow with sudden expansion with usual notations. (08 Marks)
c. The water is flowing with a velocity of 5 m/s in a pipe of length 2500 m and of diameter 500 mm. Find the sudden rise in pressure due to closure of valve. Provide at the end of pipe if it is closed in: (i) 25 seconds (ii) 2 seconds for a rigid pipe.
Take $C = 1460$ m/s, $K = 19.62$ MPa. (08 Marks)

OR

- 10 a. With a neat sketch, derive an equation for pressure rise due to sudden closure of valve at the end of an elastic pipe. (08 Marks)
b. Explain the procedure to solve pipe networks using Hardy-Cross Method. (06 Marks)
c. Three pipes of lengths 800 m, 500 m and 400 m and of diameters 500 mm, 400 mm and 300 mm respectively are connected in series. Find the equivalent size of the pipe for a total length of 1700 m. (06 Marks)
