



USN

--	--	--	--	--	--	--	--	--	--

15ENG25

Second Semester B.Arch. Degree Examination, Feb./Mar. 2022

Building Structures - II

Time: 3 hrs.

Max. Marks: 100

Note: Answer any FIVE full questions, choosing ONE full question from each module.

Module-1

- 1 a. Discuss the significance of centroid in structures and explain briefly how to find the C.G of a plane surface? Show the centroid of rectangle, triangle with neat sketch. (10 Marks)
- b. Locate the centroid for the following Fig Q1(b)

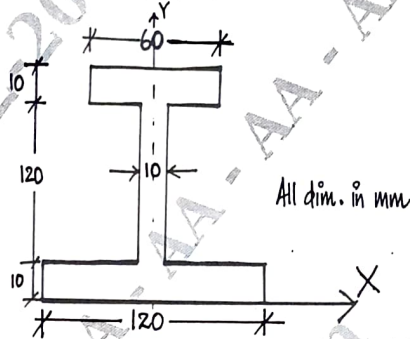

Fig Q1(b)

(10 Marks)

OR

- 2 a. Explain the concept of significance of moment of inertia and the parallel axis theorem of moment of inertia. (06 Marks)
- b. Find the moment of inertia about X-X for the T beam in Fig Q2(b).
Part 1 Width : 8cm Depth 3cm
Part 2 Width : 3cm Depth 8cm

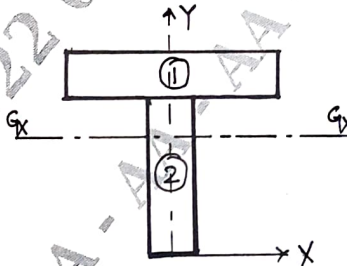

Fig Q2(b)

(14 Marks)

Module-2

- 3 a. Draw BMD and SFD for the cantilever beam shown in Fig Q3(a)

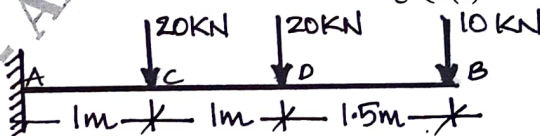

Fig Q3(a)

(10 Marks)

Important Note : 1. On completing your answers, compulsorily draw diagonal cross lines on the remaining blank pages.
2. Any revealing of identification, appeal to evaluator and /or equations written eg. 42+8 = 50, will be treated as malpractice.

- b. Draw SFD and BMD for the S.S beam shown in Fig Q3(b)

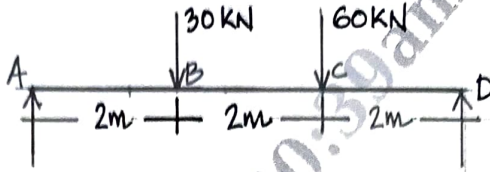

Fig Q3(b)

(10 Marks)

OR

- 4 a. Draw SFD and BMD for the cantilever beam shown in Fig Q4(a)

(10 Marks)

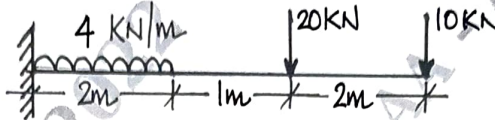

Fig Q4(a)

- b. Draw SFD and BMD for the S.S beam shown in Fig Q4(b)

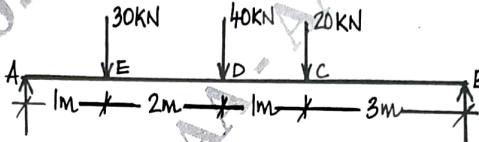

Fig Q4(b)

(10 Marks)

Module-3

- 5 a. Explain section modulus in theory of bending. Calculate the section modulus for the following :
 i) Rectangular section of size 300mm × 500mm
 ii) A circular pipe of external diameter 70mm and thickness 4mm
 b. Draw shear stress distribution indicating values at salient points. Fig Q5(b)- i) and ii)

(10 Marks)

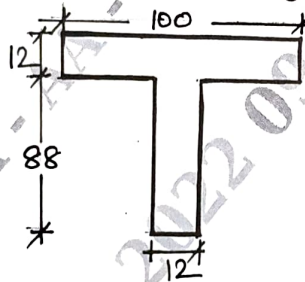

Fig Q5(b)- i)

Shear stress
 Bottom of flange – 2.675 N/mm²
 Top of web – 22.288 N/mm²
 @ neutral axis – 23.73 N/mm²

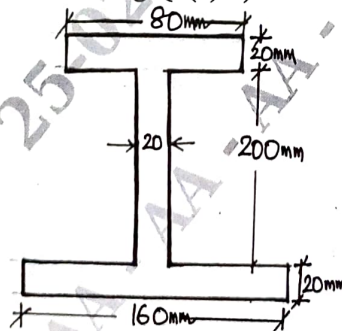

Fig Q5(b) – ii)

Shear stress
 Bottom of top flange – 1.528 N/mm²
 Top of web – 6.113 N/mm²
 @ neutral axis – 10.345 N/mm²
 Bottom of web – 8.464 N/mm²
 Top of lower flange – 1.058 N/mm²

(10 Marks)

OR

- 6 a. Determine the deflection for a cantilever beam @ free end, with concentrated load 'W' @ free end. Given $W = 40\text{kN}$, $L = 4\text{m}$, $E = 2 \times 10^5 \text{ N/mm}^2$, $I = 2 \times 10^8 \text{ mm}^4$. (10 Marks)
 b. A cast iron beam 40mm wide and 80mm deep is simply supported on a span of 1.2m. The beam carries a point load of 15kN at the centre. Find the deflection at the centre. Take $E = 108000 \text{ N/mm}^2$. (10 Marks)

Module-4

- 7 a. Write Euler's crippling load for different end conditions of a column. (08 Marks)
 b. A mild steel tube 4m long 30mm internal diameter and 4mm thick is used as a strut with both ends hinged. Find the collapsing load $E = 2.1 \times 10^5 \text{ N/mm}^2$. (12 Marks)

OR

- 8 a. Define Slenderness ratio. Write the limitations of Euler's Theory. (08 Marks)
 b. Calculate the critical load of a strut which is made of a bar, circular in section and 5m long and which is pin jointed at both end. The same bar when simply supported gives a mid span deflection of 10mm with a load of 10N at the centre. (12 Marks)

Module-5

- 9 Calculate the maximum load that can be carried by 300mm \times 300mm square column reinforced with 6 bars 16mm dia, use M20 and Fe415 grade of steel and concrete respectively. Also find allowable service load if F.S = 1.5. (20 Marks)

OR

- 10 A circular cross section of 350mm diameter size is reinforced with 6 vertical bases of 20mm diameter. Determine the strength of concrete and steel with following data :

- i) $f_c = 25\text{N/mm}^2$, $f_{ck} = 15\text{N/mm}^2$
- ii) $f_y = 415\text{N/mm}^2$, $f_{ek} = 20\text{N/mm}^2$
- iii) $f_y = 500\text{N/mm}^2$, $f_{ek} = 25\text{N/mm}^2$
