

# CBCS SCHEME

18AU71

Seventh Semester B.E. Degree Examination, Jan./Feb. 2023

## Finite Element Modeling and Analysis

Time: 3 hrs.

Max. Marks: 100

Note: Answer any FIVE full questions, choosing ONE full question from each module.

### Module-1

- 1 a. Derive the equilibrium equation for 3D elastic body. (10 Marks)
- b. For the spring system shown in Fig Q1(b). Using principle of minimum potential energy, determine the Nodal displacement take  $F_1 = 70\text{N}$  and  $F_2 = 105\text{N}$

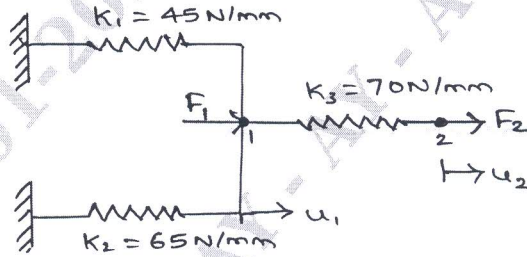

Fig Q1(b)

(10 Marks)

OR

- 2 a. With neat sketch, explain plane stress and plain strain. Also state the assumptions. (10 Marks)
- b. A bar of length  $L$ , cross sectional Area  $A$  and modulus of elasticity  $E$ , is subjected to distributed axial load  $q = cx$ , where  $C$  is a constant as shown in Fig Q2(b). Determine the displacement of the bar at the end using Rayleigh - Ritz method.

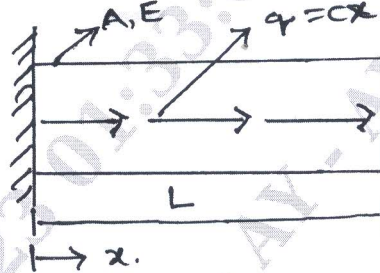

Fig Q2(b)

(10 Marks)

### Module-2

- 3 a. Use the Galerkin's method to obtain the approximate solution of the differential equation  $\frac{d^2y}{dx^2} - 10x^2 = 5$   $0 \leq x \leq 1$ . With boundary condition  $y(0) = y(1) = 0$ . Take the trial functions as  $N_1(x) = x(x-1)$  and  $N_2(x) = x^2(x-1)$ . (10 Marks)
- b. Explain basic steps involved in FEM. (10 Marks)

OR

- 4 a. Explain the stiffness matrix. Derive the stiffness matrix for the Bar element. (10 Marks)
- b. Derive the shape functions for Linear bar element in natural coordinates. (ID) (10 Marks)

Important Note : 1. On completing your answers, compulsorily draw diagonal cross lines on the remaining blank pages.  
2. Any revealing of identification, appeal to evaluator and /or equations written eg. 42+8 = 50, will be treated as malpractice.

**Module-3**

- 5 a. Determine the Nodal displacement vector for the bar shown in Fig Q5(a), using penalty approach of handling boundary conditions.

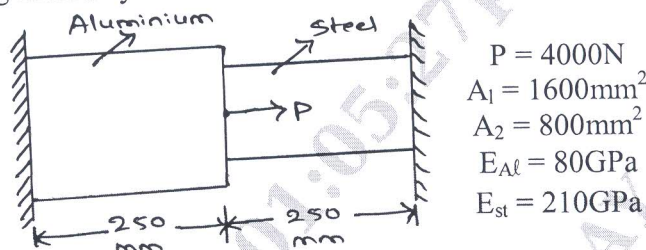

Fig Q5(a)

(10 Marks)

- b. Solve the following system of simultaneous equation by Gaussian elimination method.

$$x_1 - 2x_2 + 6x_3 = 0$$

$$2x_1 + 2x_2 + 3x_3 = 3$$

$$-x_1 + 3x_2 = 2$$

(10 Marks)

**OR**

- 6 a. Define Truss. State assumptions made in analysis of trusses. (04 Marks)
- b. For the two bar truss shown in Fig Q6(b), determine the nodal displacement and the stress in each member. Also find the support reaction. Take  $E = 200\text{GPa}$ .

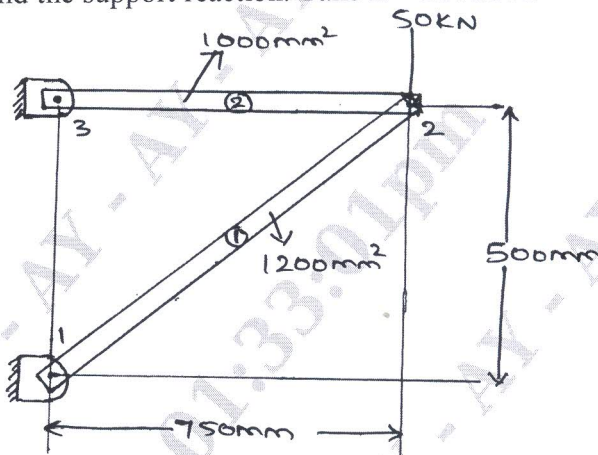

Fig Q6(b)

(16 Marks)

**Module-4**

- 7 a. With line diagram, explain isoparametric sub and superparametric elements. (10 Marks)
- b. Derive the shape functions for a three noded quadratic bar element. (10 Marks)

**OR**

- 8 a. Derive the shape function for two noded bar element (one dimensional) using Langrangian polynomial. (10 Marks)
- b. Write a short note on : (10 Marks)
- Properties of shape functions
  - Langrange interpolation function

**Module-5**

- 9 a. Fig Q9(a) shown a simply supported beam subjected to a uniformly distributed load, obtain the maximum deflection. Take  $E = 200\text{GPa}$  and  $I = 2 \times 10^6 \text{mm}^4$ .

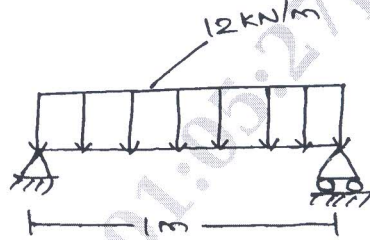

Fig Q9(a)

(10 Marks)

- b. A uniform cross sectional beam is fixed at one end supported by a roller at the other end. A concentrated 20kN is applied at the mid length of the beam as shown in Fig Q9(b). Determine the deflection under load. Take  $E = 210\text{GPa}$  and  $I = 2500 \text{mm}^4$ .

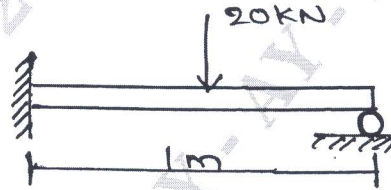

Fig Q9(b)

(10 Marks)

**OR**

- 10 a. Obtain differential equation for 1D Heat conduction. (06 Marks)  
 b. Explain Heat transfer in thin fins. (04 Marks)  
 c. Solve for temperature distribution in the composite wall as shown in Fig Q10(c), using 1-D heat elements, use penalty approach of handling boundary condition.

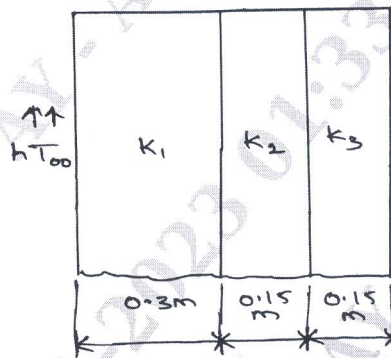

Fig Q10(c)

- $K_1 = 20\text{W/m}^\circ\text{C}$
- $K_2 = 30 \text{W/m}^\circ\text{C}$
- $K_3 = 50 \text{W/m}^\circ\text{C}$
- $T_\infty = 800^\circ\text{C}$
- $h = 25\text{W/m}^2\text{C}$

(10 Marks)

\*\*\*\*\*