

USN

| | | | | | | | | | |
|--|--|--|--|--|--|--|--|--|--|
| | | | | | | | | | |
|--|--|--|--|--|--|--|--|--|--|

18ENG15

First Semester B.Arch. Degree Examination, June/July 2023 Building Structures – I

Time: 3 hrs.

Max. Marks: 100

Note: Answer any FIVE full questions, choosing ONE full question from each module.

Module-1

- 1 Explain the properties of the following :
- i) Concrete
 - ii) Wood
 - iii) Steel
 - iv) Aluminium
 - v) Glass
- (20 Marks)

OR

- 2 a. Define the following :
- i) Dead load
 - ii) Live load
 - iii) Impact load
 - iv) Earthquake load
 - v) Static load
- (05 Marks)
- b. Explain load path in a structure with a neat figure. (10 Marks)
- c. Write a short note on concrete. (05 Marks)

Module-2

- 3 a. What is a force system? Explain the classification of force system (Any 5). (10 Marks)
- b. What is a couple? List the characteristics of a couple. (05 Marks)
- c. Find the resultant of the coplanar concurrent force system shown in the Fig.Q3(c).

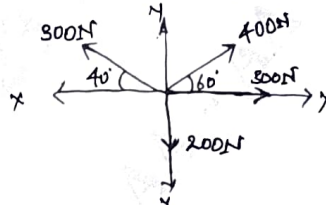

Fig.Q3(c)

(05 Marks)

OR

- 4 a. Define and explain transmissibility of force with neat sketches. (06 Marks)
- b. Define the following :
- i) Resultant
 - ii) Moment
 - iii) Reaction
 - iv) Equilibrant
- (04 Marks)
- c. Four coplanar forces acting at a point are shown in Fig.Q4(c). One of the force is unknown and its magnitude is shown by P. The resultant has a magnitude of 500 N and is acting along the x-axis. Determine the unknown force P and its inclination with the x-axis. (10 Marks)

Important Note : 1. On completing your answers, compulsorily draw diagonal cross lines on the remaining blank pages.
2. Any revealing of identification, appeal to evaluator and /or equations written eg, 42+8 = 50, will be treated as malpractice.

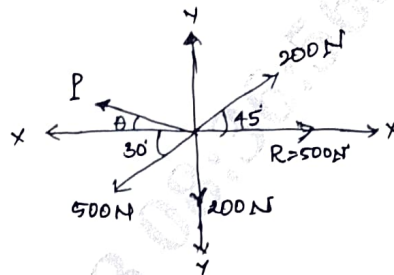

Fig.Q4(c)

Module-3

- 5 a. What are different types of supports? Explain with figure. (08 Marks)
 b. Determine the magnitude, direction of the resultant force for the force system shown in Fig.Q5(b). Also locate the resultant force with respect to point D.

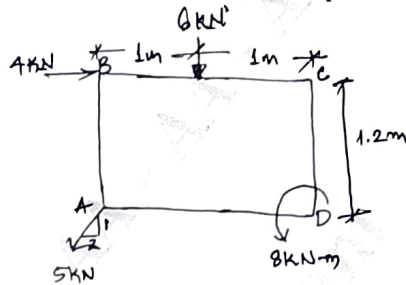

Fig.Q5(b)

(12 Marks)

OR

- 6 a. Explain different types of beams with figure. (10 Marks)
 b. Determine the reactions at A and E for the beam shown in Fig.Q6(b).

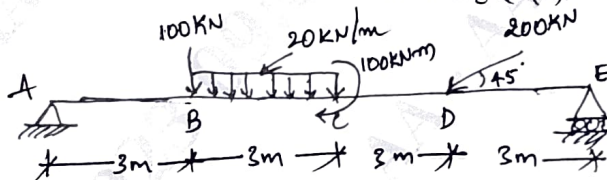

Fig.Q6(b)

(10 Marks)

Module-4

- 7 a. Find the centroid of Fig.Q7(a).

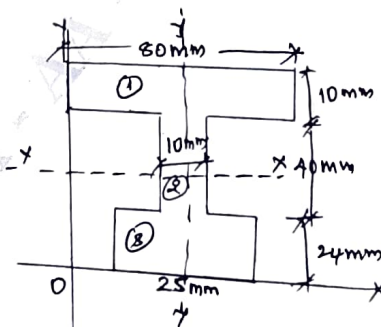

Fig.Q7(a)

(08 Marks)

- b. Determine the moment of inertia about the horizontal axis of the plane lamina shown in Fig.Q7(b). Also find radius of gyration (k) about the horizontal axis.

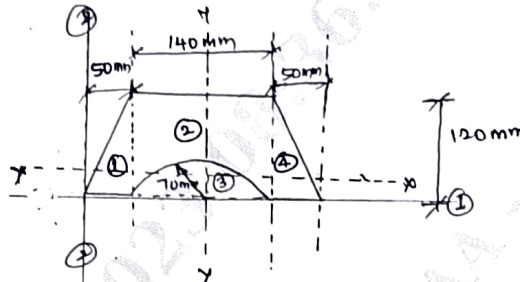

Fig.Q7(b)

(12 Marks)

OR

- 8 a. Define the following :
 i) Centroid
 ii) Centre of Gravity
 iii) Parallel axis theorem with equation (05 Marks)
- b. Determine the moment of inertia of the section shown in Fig.Q8(b) about its centroidal axis. Also calculate the least radius of gyration for the section as well.

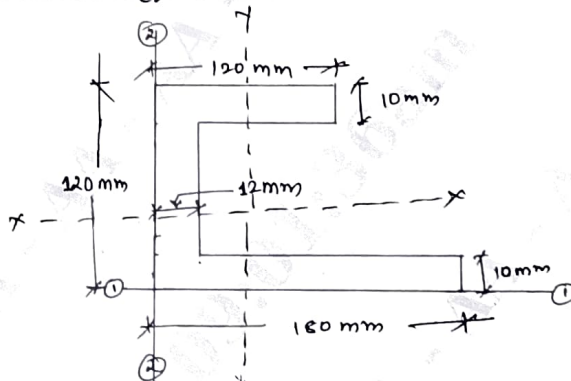

Fig.Q8(b)

(15 Marks)

Module-5

- 9 a. What are the assumptions made in the analysis of truss? (03 Marks)
 b. What are the different types of truss? Explain with figures. (09 Marks)
 c. A truss is shown in Fig.Q9(c), find the support reactions and calculate the total weight if each member has 2 angles $50 \times 50 \times 6$ @ 4.5 kg/mt each angle.

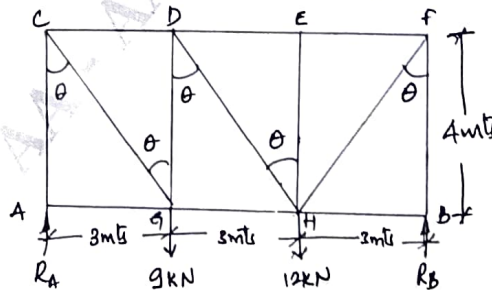

Fig.Q9(c)

(08 Marks)

OR

- 10 Analyse the truss shown in Fig.Q10 by the method of joints. Tabulate the result and indicate the nature of force in the truss.

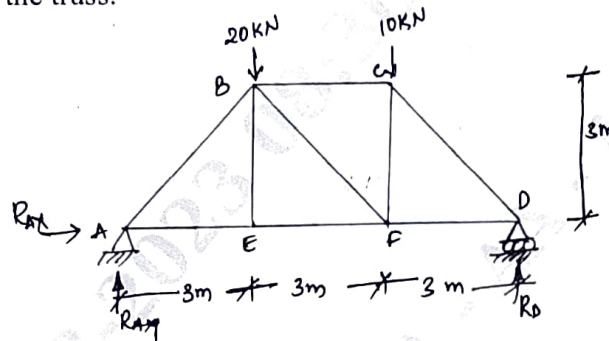

Fig.Q10

(20 Marks)
