

CBCS SCHEME

USN

--	--	--	--	--	--	--	--	--	--

21AU53

Fifth Semester B.E. Degree Examination, Dec.2023/Jan.2024

Design of Automobile Components

Time: 3 hrs.

Max. Marks: 100

- Note: 1. Answer any FIVE full questions, choosing ONE full question from each module.
 2. Missing Data is any may suitably assumed.

Module-1

- 1 a. A circular rod of diameter 60mm is subjected to load as shown in Fig Q1(a). Determine the nature and magnitude of stress at the critical points.

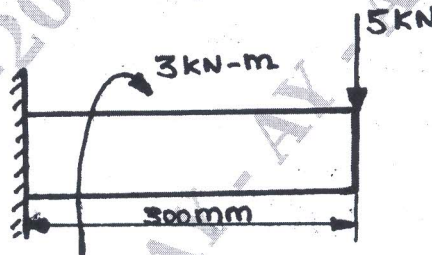

Fig Q1(a)

(10 Marks)

- b. A mild steel Bracket shown in Fig Q1(b) is subjected to a pull of 10kN. The Bracket has a rectangular cross section whose depth is twice the width. If the allowable stress for the material is 80N/mm^2 . Determine the cross section of the bracket.

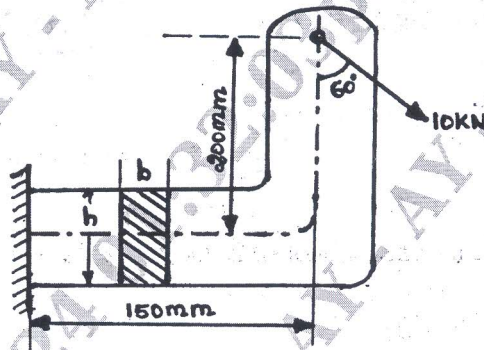

Fig Q1(b)

(10 Marks)

OR

- 2 a. A plated C45 steel ($\sigma_{yt} = 353\text{MPa}$) is subjected to the following stress $\sigma_z = 150\text{MPa}$; $\tau_y = 100\text{MPa}$; $\tau_{xy} = 50\text{MPa}$. Find the factor of safety by maximum principle stress theory and maximum shear stress theory. (10 Marks)
- b. Define Endurance Limit. State and explain the factor for modifying it. (10 Marks)

Module-2

- 3 a. Design a square key for a gear shaft of diameter 25mm. 20kW power at 100rpm is transmitted from the shaft to the gear. The yield strength of key material in tension is 450MPa and factor of safety is 3. The yield strength in compression can be assumed to be equal to the yield strength in tension. Determine dimensions of the key. (10 Marks)

Important Note : 1. On completing your answers, compulsorily draw diagonal cross lines on the remaining blank pages.
 2. Any revealing of identification, appeal to evaluator and /or equations written eg, 42+8 = 50, will be treated as malpractice.

- b. Design and sketch the assembly of a knuckle joint to connect two mild steel rods subjected to an axial pull of 100kN. The allowable stress for rods and pin are 100MPa, 130MPa and 60MPa in tension, crushing and shear respectively. The bending of the pin is prevented by selection of proper fit. (10 Marks)

OR

4. A solid steel shaft running at 600rpm is supported on bearing 600mm apart. The shaft receives 40kW through a 400mm diameter pulley weighing 400N located 300mm to the right of left bearing by a vertical flat belt drive. The power is transmitted from the shaft through another pulley of diameter 600mm weighing 800N located 200mm to the right of right bearing. The belt driver are at right angles to each other and ratio of belt tension is 3. Determine the size of shaft necessary, if the allowable shear stress in the shaft material is 40MPa and the load are steady. (20 Marks)

Module-3

5. a. A 25kW at 3000rpm to be transmitted by a multiple friction clutch. The plates have friction surface of steel and phosphor bronze. Alternatively run oil. Design the clutch for 25% over load. Take $\mu = 0.03$ and $P = 1.0346\text{MPa}$, yield stress is 294.2MPa and $D_2 = 1.5D_1$. Take FOS = 3. (10 Marks)
- b. A single block brake is shown in Fig Q5(b). The drum diameter is 250mm. The contact angle is 90° . If an operating force of 700N is applied at the end of the level and the coefficient of friction is 0.35 determine the torque that may be sustained by the brake.

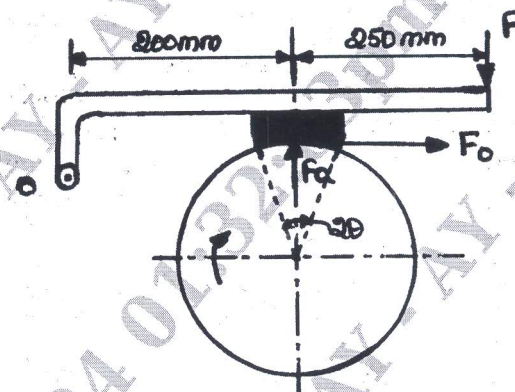

Fig Q5(b)

(10 Marks)

OR

6. a. Design a helical compression spring to support an axial load of 3000N. The deflection under load is limited to 60mm. The spring index is 6. The spring is made of chrome-vanadium steel and factor of safety is equal to 2. (10 Marks)
- b. Determine the width and thickness of 6 leaves cantilever spring 300mm long to carry a load of 1550N, with a deflection of 30mm. The maximum stress in the spring should not exceed 0.330GPa. Take $E = 204\text{GPa}$. (10 Marks)

Module-4

7. a. Explain Buckling of connecting rod. (06 Marks)
- b. Design a connecting rod for a petrol engine from the following data. Cylinder bore or diameter of piston = 100mm length of connecting rod = 350mm ; Maximum pressure or explosion pressure = 3N/mm^2 ; Length of stroke = 150mm ; Engine speed = 1500rpm ; weight of reciprocating parts 25N compression ratio = 4:1, assume any further data required for the design. (14 Marks)

OR

- 8 a. Sketch and explain different types of crank shaft. (08 Marks)
- b. Design an overhung or side crankshaft at top dead centre position, with two main bearings and flywheel in between them for an IC engine having single cylinder $250\text{mm} \times 300\text{mm}$. The flywheel cum belt pulley weights 10kN . The maximum pressure is 2MPa . The ratio of length of connecting rod to crank length is 4.5 , total belt pull is 5kN . The torque is maximum when the crank angle is at 35° from inner dead center. The gas pressure at this instant is 1.05MPa . Width of hub for flywheel cum belt pulley is 200mm . Assume any further data required for the design. (12 Marks)

Module-5

- 9 a. Sketch and explain : i) Flat plate type head piston ii) Cup type head piston. (10 Marks)
- b. Design cast iron piston for a single acting four stroke diesel engine from the following data. Cylinder bore = 100mm ; Length of stroke = 125mm ; Speed = 2000rpm ; Brake mean effective pressure = 0.5MPa ; Maximum gas pressure = 5MPa ; Fuel consumption = 0.25Kg/Bp in kW/Hr . (10 Marks)

OR

- 10 a. With a neat sketch, explain single row overhead valve mechanism. (10 Marks)
- b. State the necessity of valve operators. With a neat sketch explain free type of valve rotator. (10 Marks)
